

Description

The SMC name derives from SubMiniature C (the third subminiature design). The SMC design was developed in the 1960's. SMC has threaded coupling with 10-32 threads.

Available in 50 & 75 ohm impedance.

Utilizes die cast components on non-critical areas to provide a low cost solution.

Features/Benefits

- Broadband performance with low reflection DC to 10 GHz provides low cost connector combined with high quality.
- Conforms to the interface dimensions of MIL-STD-348 provides intermatability with other connector suppliers. Offers customer second source.
- 10-32 screw-on (threaded) coupling mechanism allows performance to 10 GHz with low reflection.
- Right Angle connectors available in one piece construction ensures better performance combined with low cost.

Application

- Antennas
- Automotive (GPS)
- Base Stations
- Cable Assemblies
- Components
- Instrumentation
- PC/LAN
- Process Controls
- Radio Boards
- Surge Protection
- Telecom
- Test and Measurement
- Video Systems

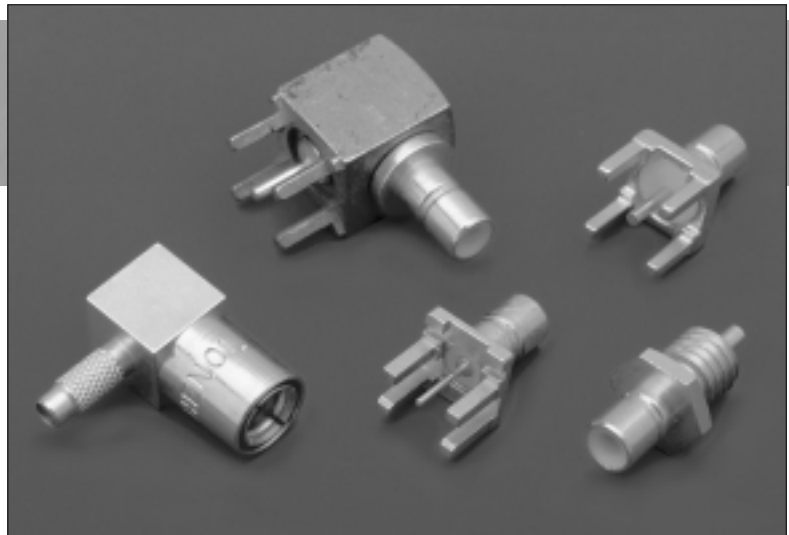

SMC Connectors

Specifications	52
Plugs, Jacks, Receptacles	53
Straight and Right Angle PCB	54

ELECTRICAL

Impedance	50 ohms
Frequency range	0-4 GHz with low reflection; usable to 10.0 GHz
Voltage rating	Sea level: 335 volts 70,000 ft: 85 volts
Dielectric Withstanding voltage (max.)	750 VRMS RG-196 1000 VRMS for RG-188 type
VSWR straight connectors rt. angle connectors	RG-196/U series 1.30 + .04 f (GHz) 1.45 + .06 f (GHz)
straight connectors rt. angle connectors	RG-188/U series 1.25 + .04 f (GHz) 1.35 + .06 f (GHz)
Contact resistance	
Center: initial	6.0 milliohms
after environ.	8.0 milliohms
Outer: initial	1.0 milliohms
after environ.	1.5 milliohms
Braid to body: initial	1.0 milliohms
after environ.	N/A
Insulation resistance	1000 megohms min.
RF leakage	-55 dB min. @ 2-3 GHz
Insertion Loss	
straight connectors	0.30 dB @ 1.5 GHz
rt. angle connectors	0.60 dB @ 1.5 GHz

MECHANICAL

Mating	50 Ohm screw-on coupling per MIL-STD-348
Mating torque	Recommended 2-3" lbs. maximum 6.2" lbs. 80-110 N.cm
Connector affixment to cable	Braid and Jacket: hex. crimp
Cable affixment to center contact	Solder
Contact captivation	All types, except as noted
Cable retention	Equal to breaking strength of cable employed
Connector durability	500 mating and unmating cycles min.

MATERIAL

Bodies	Brass per QQB-626 or zinc per ASTM B86-71, as specified, nickel or gold plated as listed
Center contacts	Female: beryllium copper, gold plated Male: brass or beryllium copper, gold plated
Outer contact	Nickel or gold plated as listed
Crimp ferrules	Annealed copper alloys
Insulators	TFE

ENVIRONMENTAL

Temperature range	-65°C to + 165°C
Thermal shock	MIL-Std. 202 method 107 condition C
Vibration	MIL-Std. 202 method 204 condition D
Shock	MIL-Std. 202 method 213 condition C
Corrosion	MIL-Std. 202 method 101 condition B

PLUG

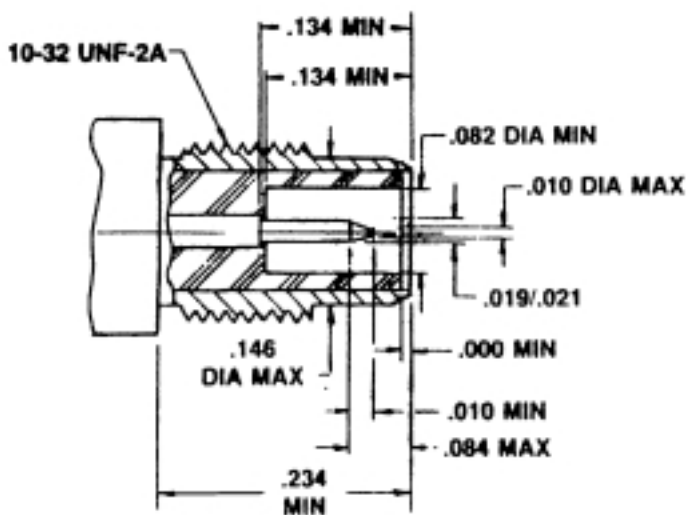

JACK

