

Description

APC stands for Amphenol Precision Connectors and was developed by Amphenol and Hewlett-Packard engineers. The Precision family is comprised of APC-2.4, APC-3.5, APC-N, APC-7.

Amphenol's APC is the first instrument-grade coaxial connector line to achieve repeatable TE11 mode resonance-free signal transmission from DC to 50 GHz with a minimum return loss of 26 dB.

These 50 ohm connectors are designed primarily for use in test and measurement equipment where reliable performance through repeated connect/disconnect cycles is critical.

Features/Benefits

- Interface dimensions which minimize distortion/deterioration of the mating surfaces.
- Fixed bead-contact assembly which prevents transmission of mating torques to circuit elements.
- M7x0.75 thread for coupling durability and small overall connector size.
- Mating sequence in which the outer conductors before the center contacts meet, eliminating female center contact damage during mating.
- Plug coupling nut that extends beyond the male center contact to protect the contact while in the unmated condition.

Application

- Cable Assemblies
- Instrumentation
- Military
- Radio Astronomy
- Satcom



APC 2.4

Specifications	86
Plugs & Jacks	87
Adapters	88

APC 3.5

Specifications	89
Plugs & Jacks	90-92

APC 7

Specifications	93
Connectors	94
Components & Accessories	95

APC N

Specifications	96
Plugs & Jacks	97

The initial Amphenol® APC-2.4™ offering includes the male and female connectors for termination to 2.4mm rigid coaxial airline and twenty-two between-series adapters for high performance transitions from the 2.4mm interface to six other microwave coaxial connectors: APC-3.5®, APC-7®, APC-N, SMA, and the Wiltron K - connector.™*

*K connector is a trademark of Wiltron Co.

Features/Benefits

- DC to 50 GHz — provides highly accurate measurements which eliminate the need for costly waveguide components
- M7 x .075 coupling — provides durability and small overall connector size
- Mating sequence outer connector first — eliminates female center conductor contact damage during mating
- Coupling nut extends beyond male center contact — protects center conductor while in the unmated condition

Specifications

ELECTRICAL

	Test Requirement
Impedance	50 ohms
Frequency range	DC-50 GHz
Return loss (min.)	
DC to 18 GHz:	>36 dB
18 to 26.5 GHz:	>32 dB
26.5 to 50 GHz:	>26 dB
Insertion loss:	≤0.06 dB
Contact resistance	
Inner:	< 1.5 milliohms
Outer:	< 0.8 milliohms
Voltage rating:	400 Vrms
Dielectric Withstanding	
Voltage (max.):	1200 Vrms
Max. power (watts @ sea level)	1000 W/ √f (MHz)

* These characteristics are typical and may not apply to all connectors.

ENVIRONMENTAL

Temperature range	-70°C to + 80°C
-------------------	-----------------

MECHANICAL

Mating	M7 x 0.75 threaded coupling
Recommended Mating torque	8 to 10 inch pounds (0.9 to 1.1 N-m)

MATERIAL

Body	Gold plated beryllium copper
Coupling Nut	Passivated stainless steel
Body	Gold plated beryllium copper

NOTE: For mated pair APC-2.4 connectors on 2.4mm airlines.

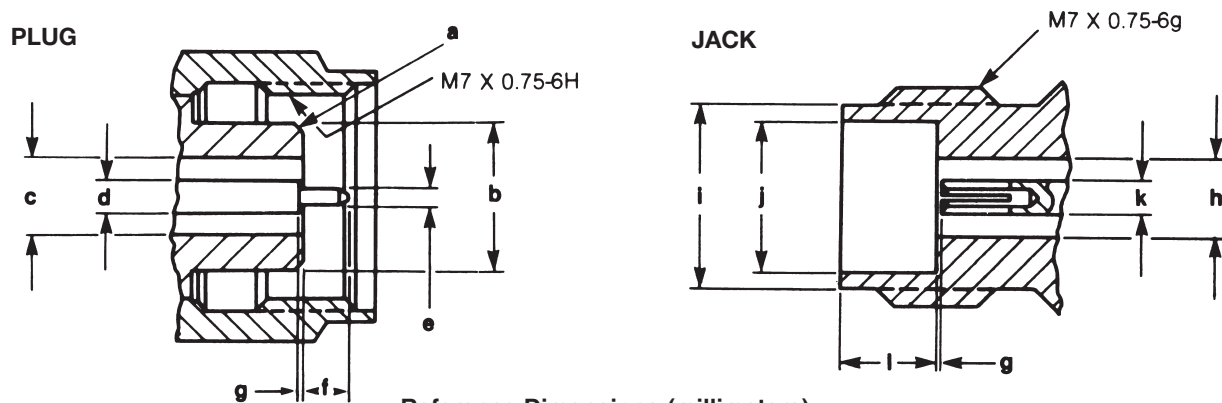

Reference Dimensions (millimeters)

a 0.25/0.36 x 45°	e ∅ 0.511 ±0.005	i ∅ 5.84 ±0.005
b ∅ 4.75 ±0.025	f ∅ 1.39 ±0.06	j ∅ 4.77 ±0.0025
c ∅ 2.400 ±0.005	g ∅ 0.000 ±0.053	k ∅ 1.042 ±0.0025
d ∅ 1.042 ±0.0025	h ∅ 2.400 ±0.005	l ∅ 3.05 ±0.05

Amphenol® APC-3.5® connectors are a high performance, 50 ohm coaxial connector designed to exhibit low VSWR, low loss, and be resonance free to 34 GHz.

Features/Benefits

- Connectors are designed for use with 3.5mm rigid airline, .085 and .141 semi-rigid cable.
- Air dielectric mating face and thicker outer conductor shoulder.
- APC-3.5 design maintains mechanical and electrical integrity through repeated mating cycles.
- APC-3.5 will mate with SMA connectors.
- Provides VSWR performance typical of SMA mated pairs up to 18 GHz.

Instructions for assembling APC-3.5 connectors to 3.5mm airline are given on page XX.

Specifications

ELECTRICAL

	Test Requirement
Impedance	50 ohms
Frequency range	0-34 GHz
VSWR	Connectors on airline 1.01 + .004f (GHz)
Insertion loss (in dB)	.015 √ f (MHz)
RF Leakage	> 100 dB @ 26.5 GHz
Contact resistance	Inner: < 2.0 milliohms Outer: < 0.4 milliohms
Voltage rating:	500 Vrms
<u>Dielectric Withstanding</u> Voltage (max.):	1500 Vrms
<u>Max. power</u> (watts @ sea level)	2.5 kW / √ f (MHz) above 1 (MHz)

ENVIRONMENTAL

Mating	1/4-36 threaded coupling
--------	--------------------------

MECHANICAL

Body and Coupling Nut	Gold plated beryllium copper
Center Contacts	Gold plated beryllium copper

MATERIAL

Temperature range	-65°C to + 85°C
Humidity	20 to 80% RH
Pressure	590 to 780 mm Hg

PLUG

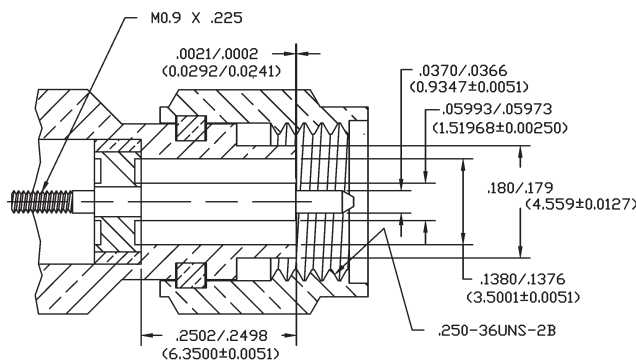

JACK

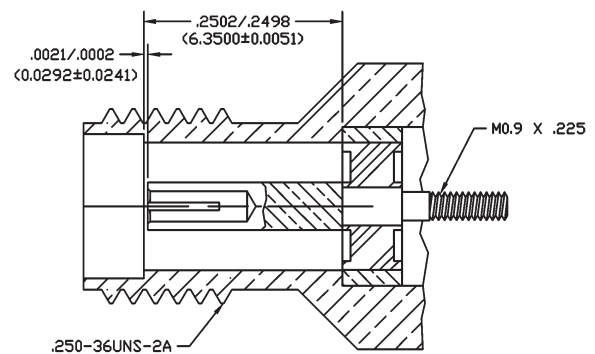

APC-7™ Coaxial Connectors

Amphenol® APC-7™ connectors are precision devices which provide long life and accurate, repeatable performance in test and instrumentation applications.

Features/Benefits

- Primarily for use with rigid 7mm airline (7mm = the inner diameter of the airline outer conductor).
- Designs are also available for use with .250 semi-rigid cable, and RG-214/U flexible cable.
- Coupling mechanism is sexless thus permitting any two APC-7 connectors to be mated.
- A certified test report of VSWR will be provided when a mated pair of APC-7 connectors is ordered (131 - 91050).

NOTE: A fluted nut design is provided as an option to APC-7 connectors. To order the fluted nut configuration, simply delete the "9" from the core part number; for example:

131-91051 Hex Knurled Nut
131-1051 Fluted Nut

Specifications

ELECTRICAL

	Test Requirement
Impedance	50 ohms
Frequency range	0-18 GHz
VSWR	Connectors on airline $1.003 + .002f$ (GHz)
Insertion loss (in dB)	$< 7 \times 10^{-3} \sqrt{f}$ (MHz) example: 0.028 dB at 16.0 GHz)
RF Leakage	$<$ signal inside coaxial line by ratio > 120 dB
Electrical length	.693 inches (1.76 cm)
Contact resistance	Inner: < 1.0 milliohms Outer: < 0.1 milliohms
Voltage rating:	1000 Vrms
Dielectric Withstanding Voltage (max.):	2500 Vrms
Max. power (watts @ sea level)	Above 1 MHz = $10kW / \sqrt{f}$ (MHz) up to 1 MHz = 10kW

ENVIRONMENTAL

Mating	Sexless, coplanar by means of threaded ring housed within coupling nut
Life	> 5000 connect/disconnect operations

MECHANICAL

Coupling mechanism	Stainless steel
Body	Gold plated beryllium copper
Center Contacts	Gold plated beryllium copper
Dielectric support	Air-polyphenylene oxide composite
Clamping components	Nickel plated brass
Crimp ferrule	Nickel plated copper

MATERIAL

Temperature range	Storage: -65°C to + 85°C Operating: -13°C to + 33°C
Humidity	20 to 80% RH
Pressure	590 to 780 mm Hg

PLUG

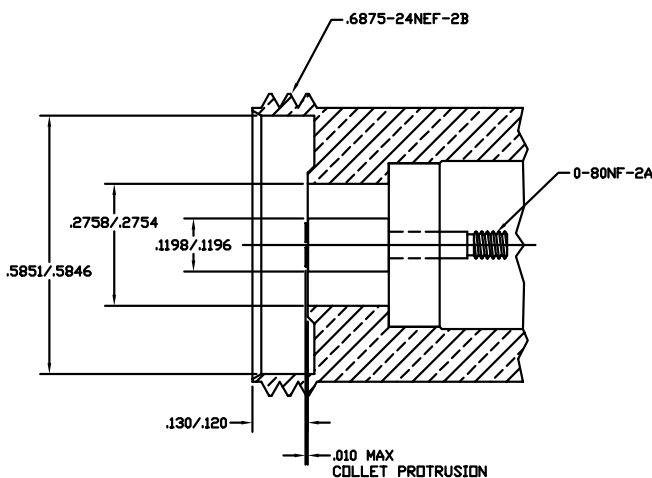

JACK

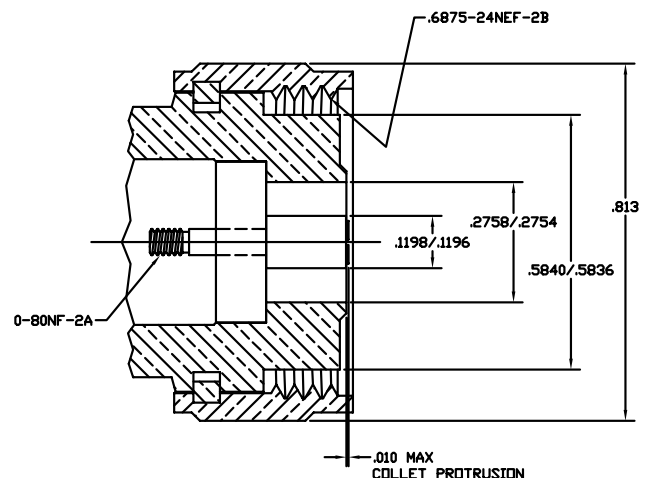

APC-N Coaxial Connectors

Amphenol® APC-N connectors can be used interchangeably with the APC-7 on rigid air line or equipment and mates with all other Type N connectors.

VSWR for a mated pair of APC-N connectors is 1.06 through 12.4 GHz and 1.08 through 18 GHz.

Specifications

ELECTRICAL

	Test Requirement
Impedance	50 ohms ± 0.1 Ohms
Frequency range	0-18 GHz
VSWR	Connectors on airline 1.08 max. to 18 (GHz)
Insertion loss (in dB)	$< 3 \times 10^{-2} \sqrt{f} \text{ (GHz)}$
RF Leakage	< signal inside coaxial line by ratio > 90 dB
Contact resistance	Inner: < 10 milliohms Outer: < 1.1 milliohms
Voltage rating:	1000 Vrms
Dielectric Withstanding	
Voltage (max.):	2500 Vrms
Max. power (watts @ sea level)	Above 1 MHz = 10kW/ $\sqrt{f} \text{ (MHz)}$ up to 1 MHz = 10kW

MECHANICAL

Mating	¹¹ / ₁₆ -24 threaded coupling. Mating dimensions are MIL-C-39012 Class II nominal with tighter tolerances. The APC-N mates with all existing Type N connectors including MIL-C-71
--------	--

MATERIAL

Body & coupling nut	Stainless steel
Center Contacts	Gold plated beryllium copper
Bead Assembly	Air-polyphenelene oxide composite
Clamping components	Nickel plated brass
Crimp ferrule	Nickel plated copper

ENVIRONMENTAL

Temperature range	Storage: -55°C to + 70°C Operating: -13°C to + 33°C
Humidity	20 to 80% RH
Pressure	590 to 780 mm Hg

* These characteristics are typical and may not apply to all connectors.

VSWR of a mated pair of APC-N connectors

